













INTERCON
FURNITURE FOR LIFE

ASSEMBLY INSTRUCTION

DESCRIPTION: 56" SIDEBORD

ITEM NO: BY-CA-5640-WHT-C / BY-CA-5640-BLK-C

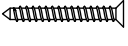
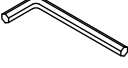
Thank you for purchasing this quality product. Be sure to check all packing material carefully for small parts which may have come loose inside the carton during shipment. Identify and count all parts and compare with the parts list below. Please keep all hardware out of reach of small children.

| | | | | | | | |
|--|---|--|--|---|--|---|--|
| 1  CABINET 1 PC | 2  FRONT KD LEG LEFT 1 PC | 3  FRONT KD LEG RIGHT 1 PC | 4  BACK KD LEG LEFT 1 PC | 5  BACK KD LEG RIGHT 1 PC | 6  SIDE STRETCHER- L 1 PC | 7  SIDE STRETCHER- R 1 PC | 8  CENTER STRETCHER 1 PC |
| A  BOLT M6 x 25mm 4 PCS | B  SPRING WASHER M6 x 10 4 PCS | C  FLAT WASHER M6 x 16 4 PCS | D  WOOD SCREW M4 x 40 6 PCS | E  ALLEN KEY M4 1 PC | F  TIPPING RESTRAINS 1 SET | | |

STEP 1

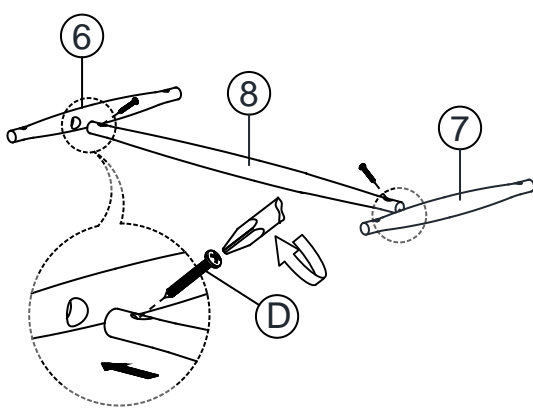

STEP 2

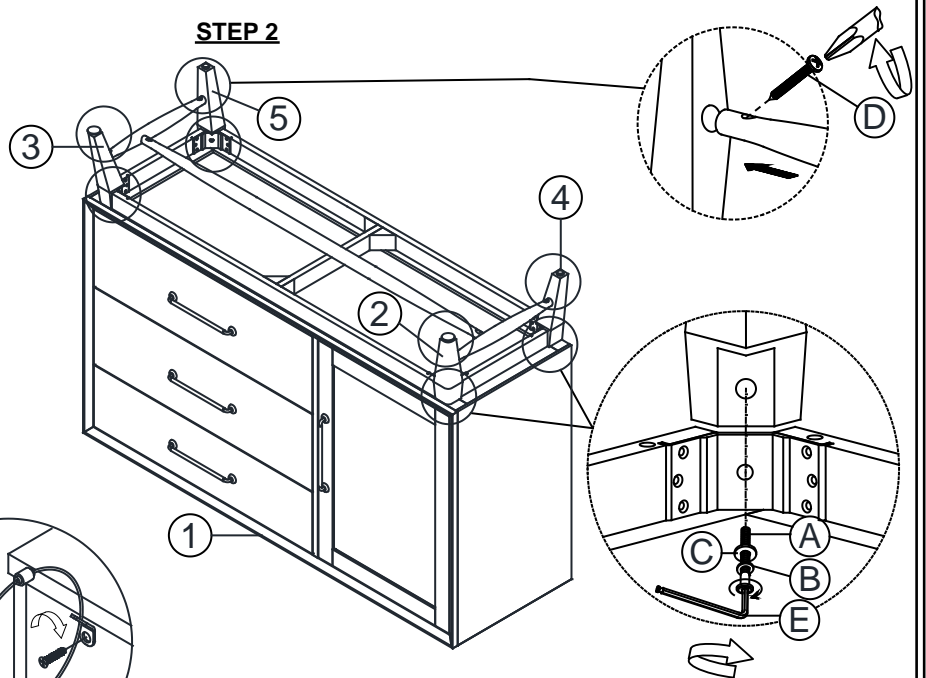

STEP 3

"SUGGEST POSITIONING THE TIPPING STRAP AS CLOSE AS POSSIBLE TO THE TOP CENTER BACK OF THE CASE"
"REFER TO TIPPING KIT MANUFACTURER'S INSTRUCTIONS FOR ATTACHMENT"

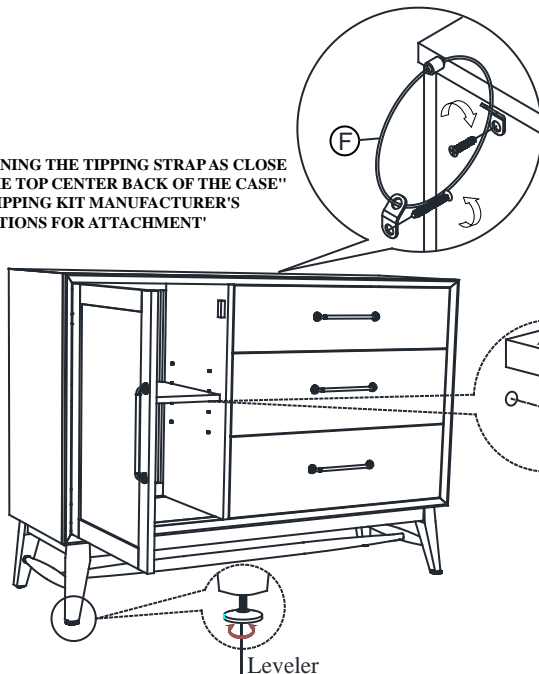

ASSEMBLY TIPS:

1. Remove hardware from box and sort by size.
2. Please check to see that all hardware and parts are present prior start of assembly.
3. Please follow attached instructions in the same sequence as numbered to assure fast and easy assembly.

⚠ WARNING!

1. Don't attempt to repair or modify parts that are broken or defective. Please contact the store immediately.
2. This product is for home use only and not intended for commercial establishments.