



INTERCON
FURNITURE FOR LIFE

ASSEMBLY INSTRUCTIONS

ITCO

ITEM : 1407-CTT / RV-TA-R4848G-CHL-TOP
1407-CTB / RV-TA-R4848G-CHL-BSE
DESCRIPTION : 1407-CTT CNT HGT TRE
1407-CTB CNT HGT TRE

SKU : 43014074
43114076

Thank you for purchasing this quality product. Be sure to check all packing material for small parts which may have come loose inside carton during shipment. Identify and count all parts and compare with the hardware list as below:

	No.	Picture	Description	Dimension	Qty
Hardware List	①		JCBB (M8) with washer	8 x P1.25 x 45mm	8 Pcs
	②		JCBB (M8) with washer	8 x P1.25 x 20mm	6 Pcs
	③		Allen Wrench (M5)	5 x 58mm	1 Pc
Parts List	No.	Description			Qty
	A	Table Top			1 Pc
	B	Table Leg			2 Pcs
	C	Metal Rail			1 Pc

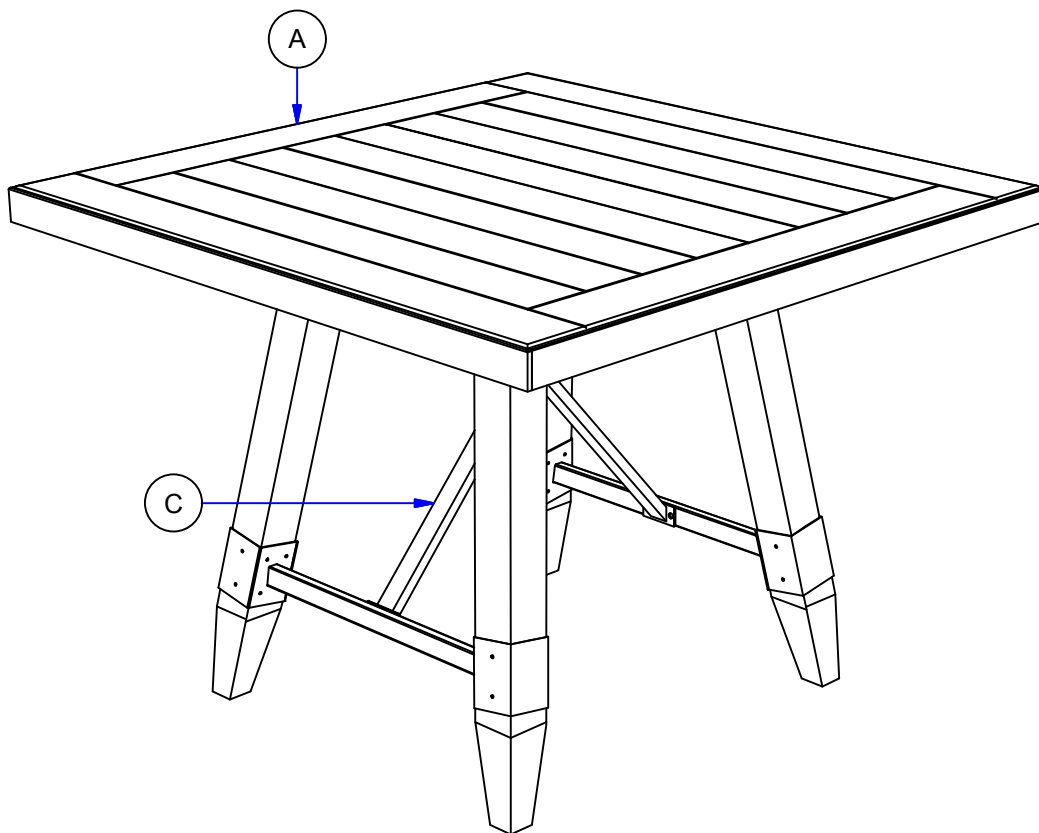

PARTS DETAIL

Assembly steps

STEP 1

Assemble Table Leg to the Table Top.

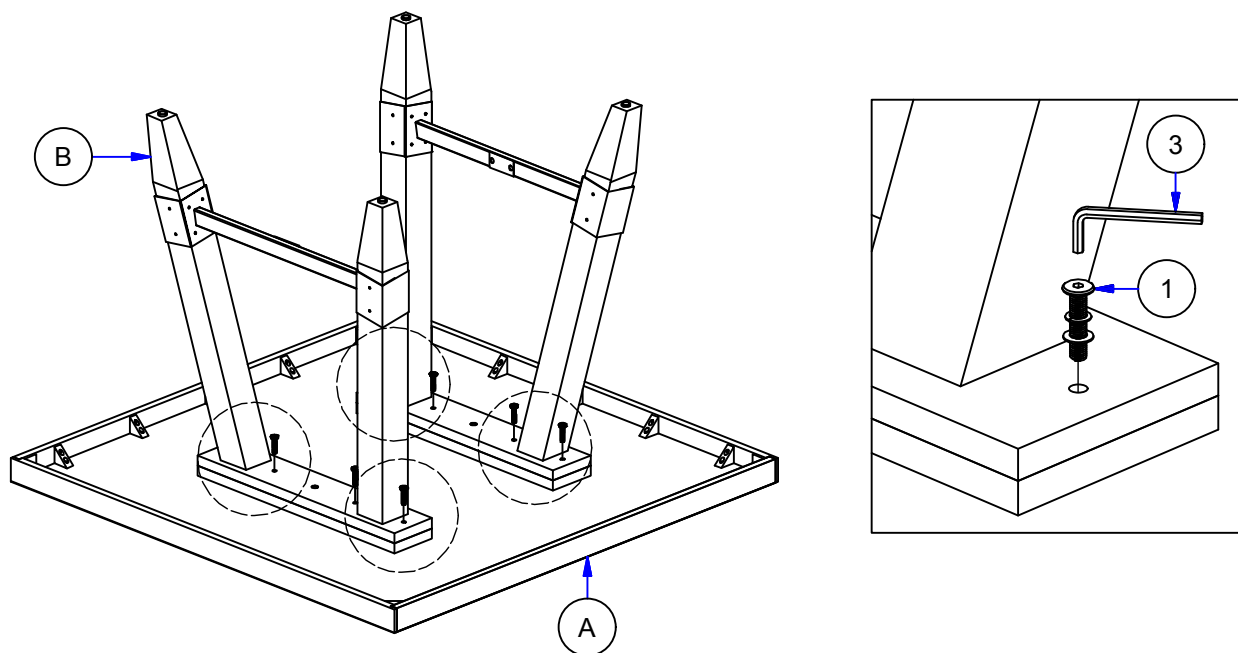

STEP 2

Assemble Metal Rail to Table Top & Table Leg.

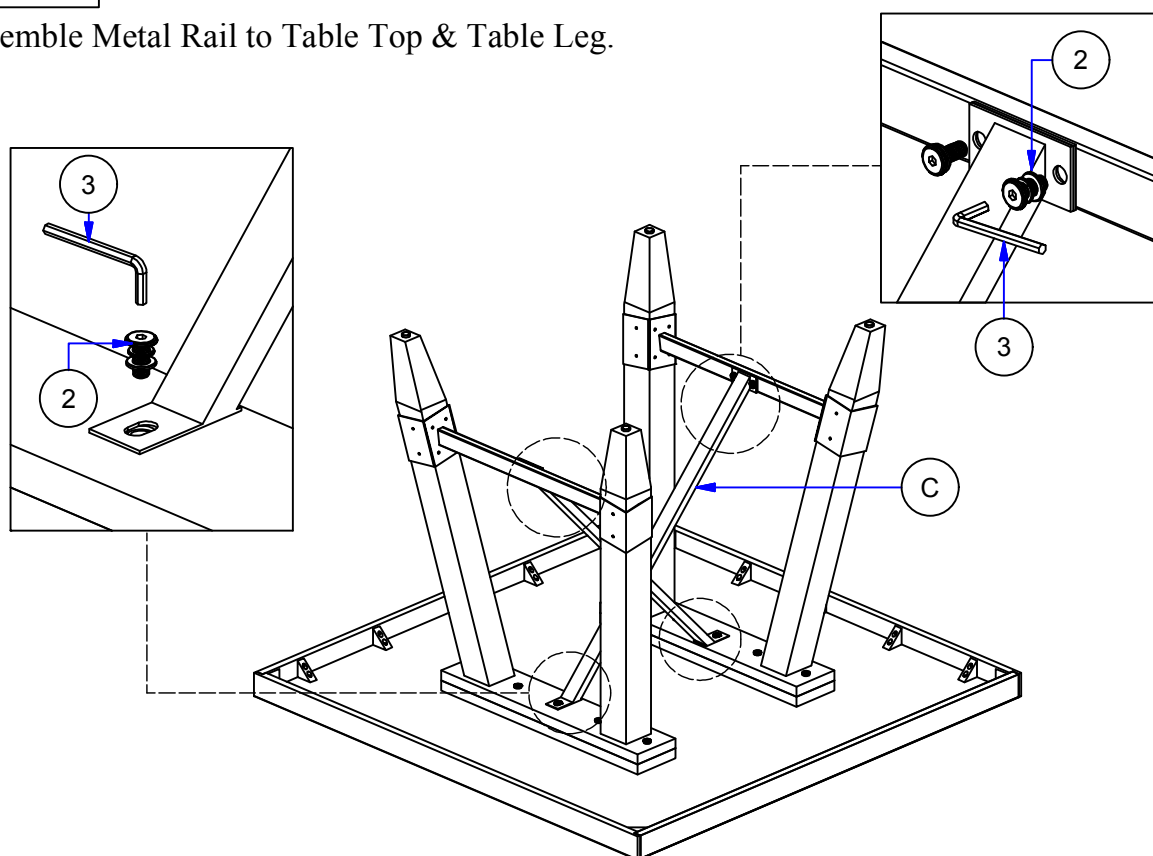

NOTE :

To ensure that table is levelled, assemble the table on flat & soft surface. DO NOT tighten all the screws & bolts until the table been adjust & level all the legs so that they do not wobble. Once adjusted then only tighten all the screws using Allen Key while making sure the unit remain level.