

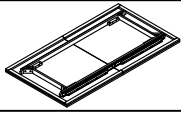

# ASSEMBLY INSTRUCTIONS

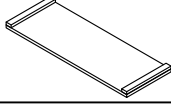

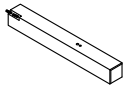

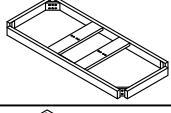
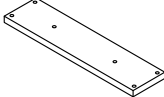
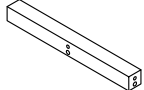
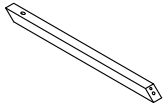
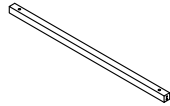



ITEM NO : ST- TA- 3884- BDY- C

Thank you for purchasing this quality product. Be sure to check all packing material carefully for small parts that may have come loose inside the carton during shipment. Please keep all hardware out of reach of small children

**PARTS LIST :**

NO.	DESCRIPTION	SKETCH	QTY
A	Table Top		1 pc
B	Table Leaf		1 pc
C	Table Leg Left- Right		4 pcs
D	Base Frame		1 pc
E	Mounting Plate		2 pcs
F	Side Stretcher		2 pcs
G	Trestle Bar		2 pcs
H	Bottom Rail		1 pc
I	Cap		4 pcs

**HARDWARE LIST :**

NO.	DESCRIPTION	SIZE	SKETCH	QTY
J	Long Bolt	φ1/4"x 85mm		4 pcs
K	Spring Washer	φ5/16"x φ12mm		30 pcs
L	Small Washer	φ1/4"x φ12mm		10 pcs
M	Allen Wrench	58x 23x 4mm		1 pc
N	Short Bolt	φ1/4"x 57mm		18 pcs
O	Flat Washer	φ5/16"x φ19mm		20 pcs
P	Hex Nut	φ5/16"x12mm		8 pcs
Q	Wrench	12x 75mm		1 pc
R	Wood Cap	Ø13x 7mm		2 pcs

**STEP 1**

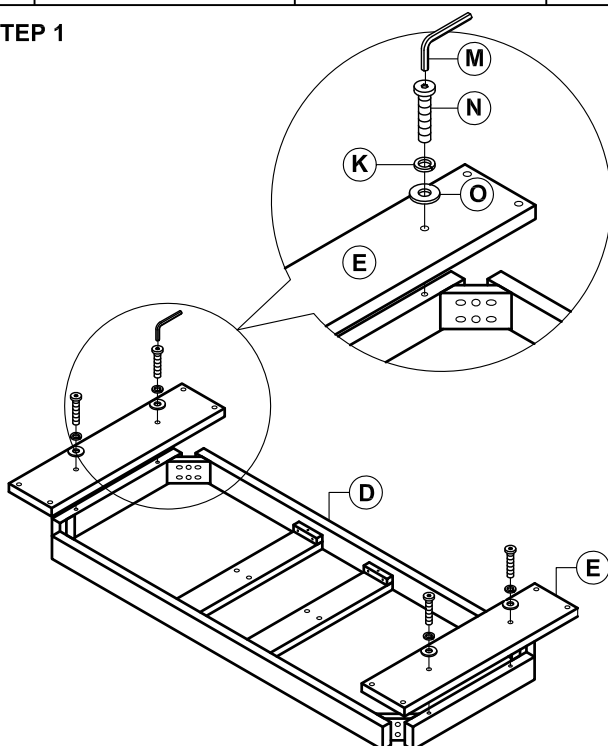

**STEP 2**

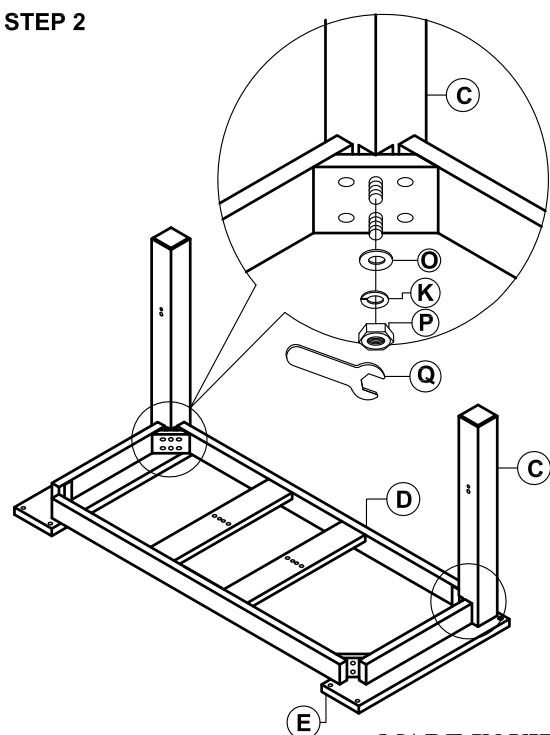

**MADE IN VIETNAM**

STEP 3

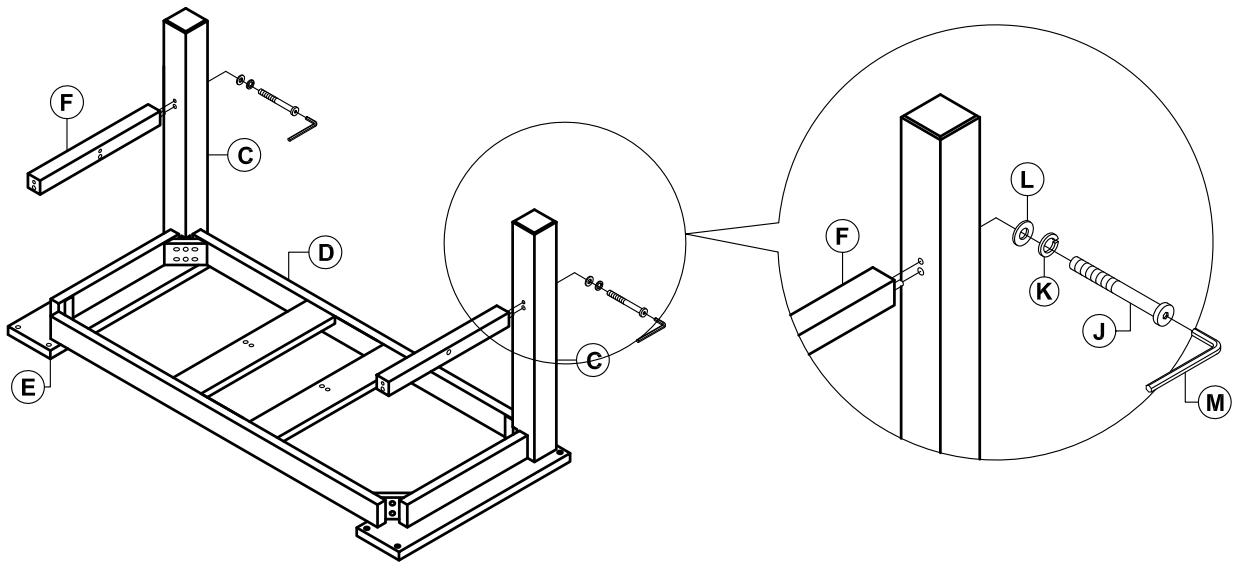

STEP 4

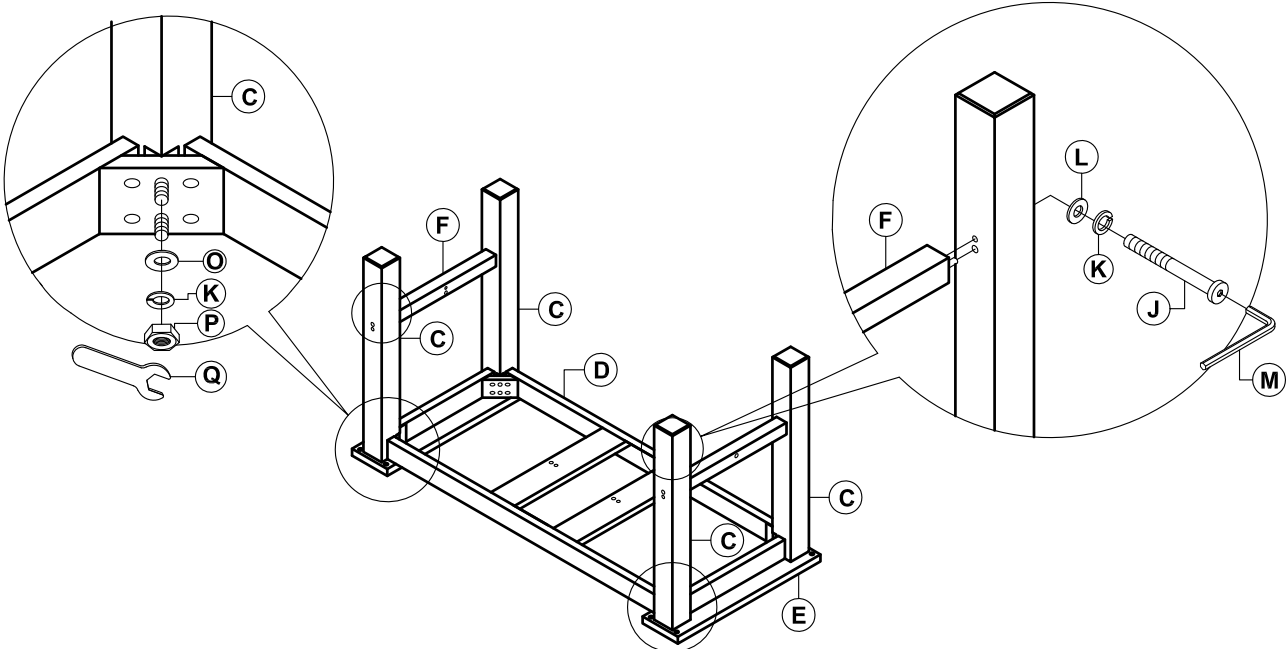

STEP 5

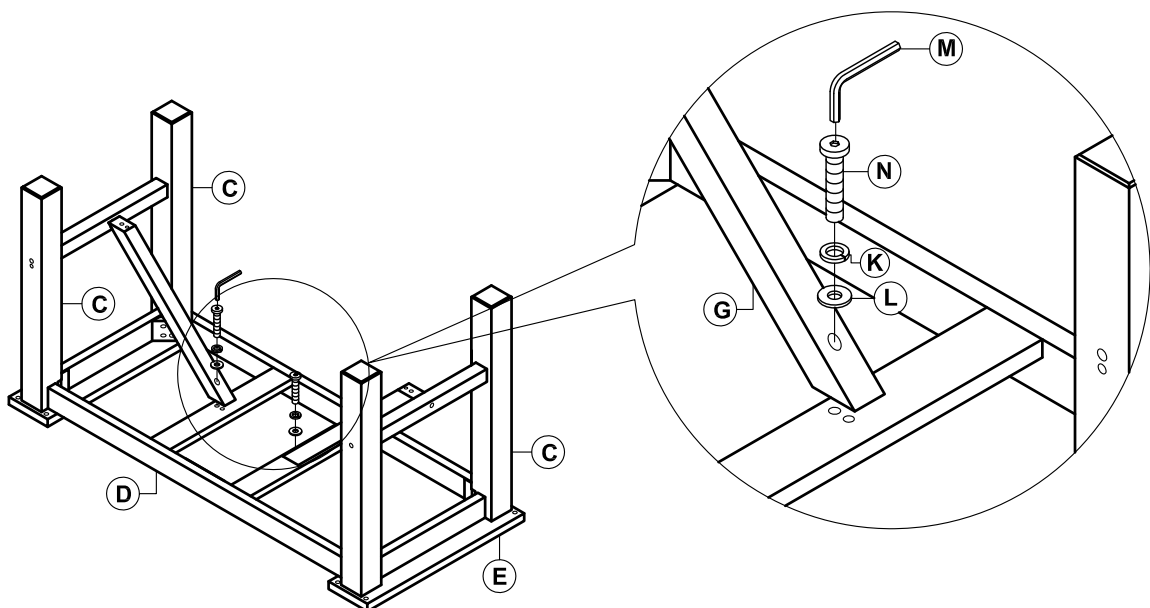

MADE IN VIETNAM

STEP 6

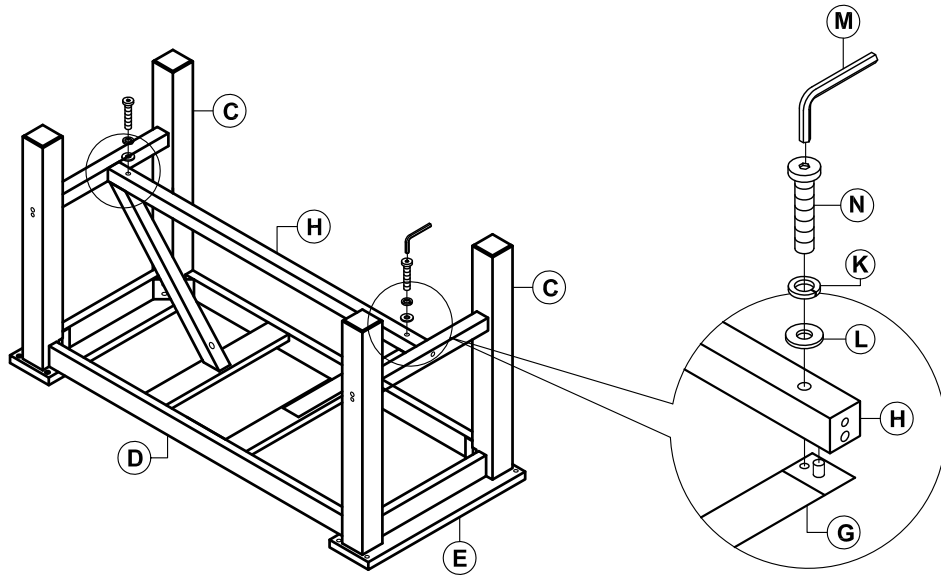

STEP 7

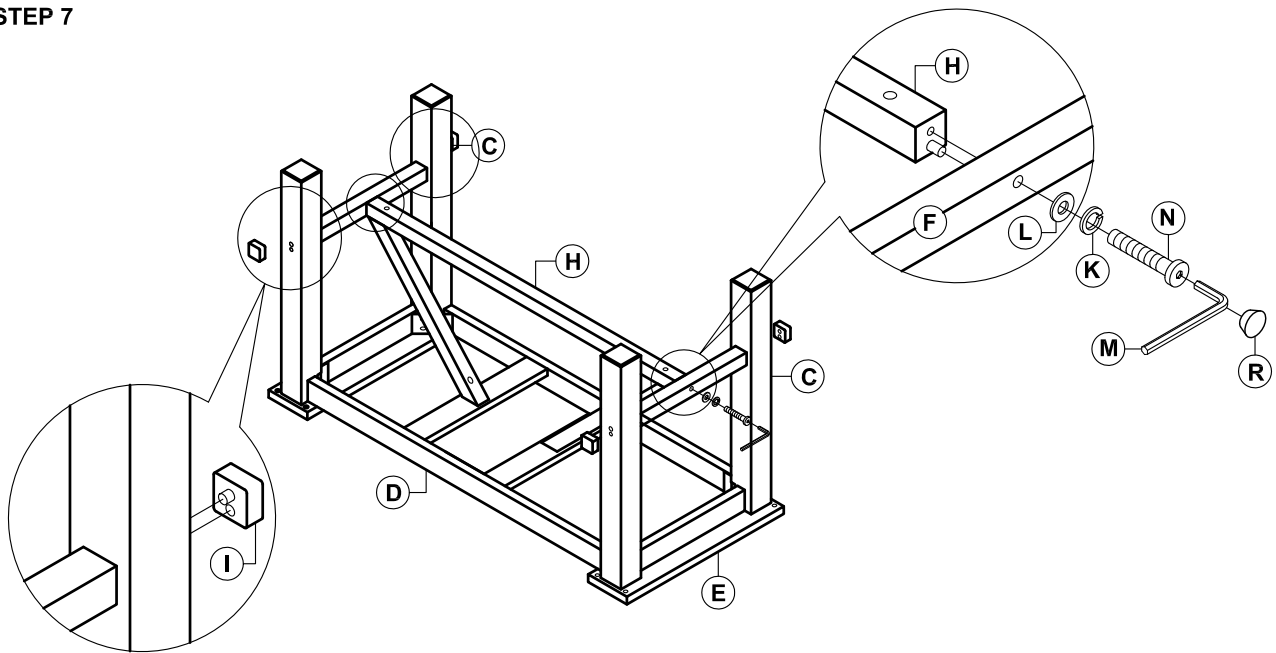

STEP 8

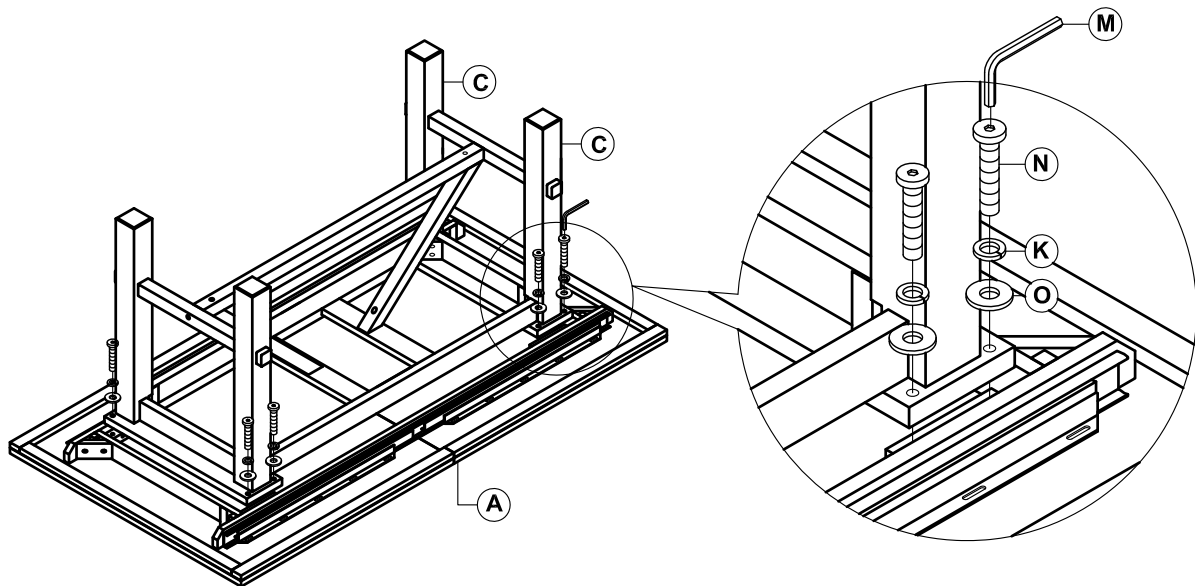

MADE IN VIETNAM

STEP 9

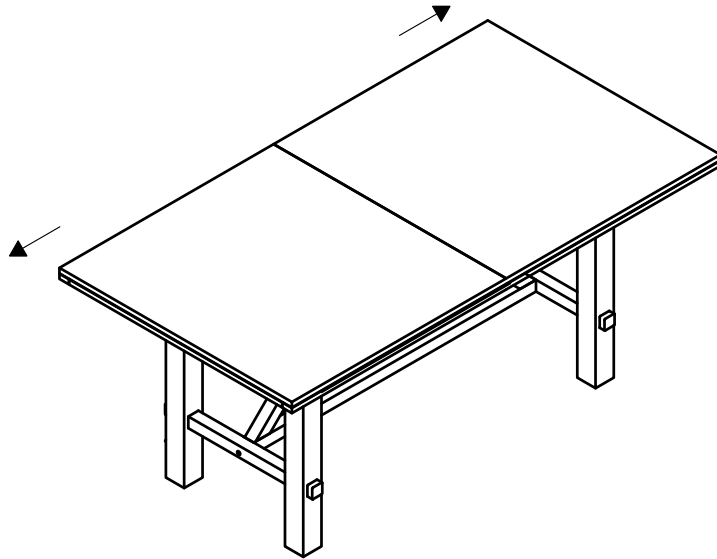

STEP 10

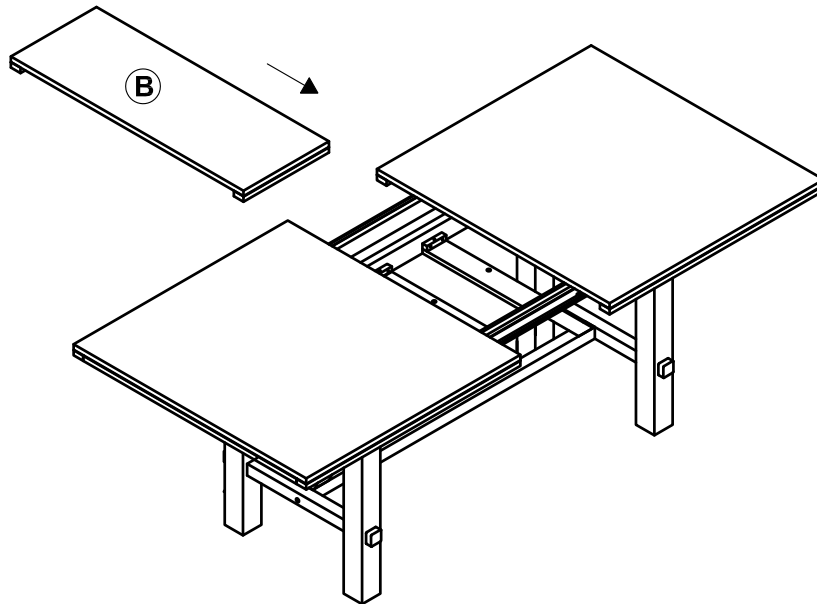

STEP 11

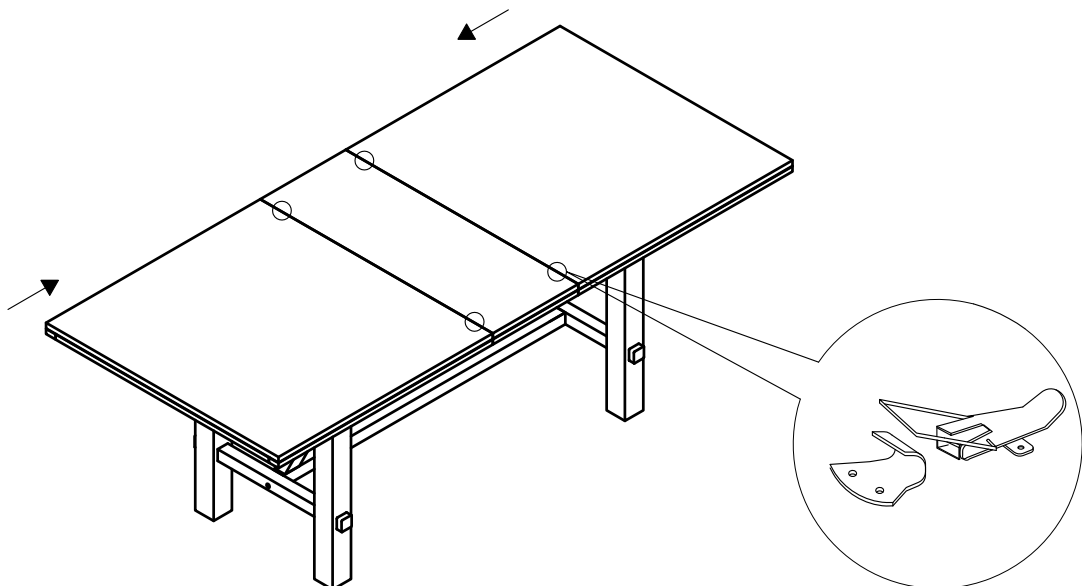

MADE IN VIETNAM