

ASSEMBLY INSTRUCTIONS

ITEM NO : KA- TA- 38130- RAI- TOP

KA- TA- 38130- RAI- BSE

Thank you for purchasing this quality product. Be sure to check all packing material carefully for small parts that may have come loose inside the carton during shipment. Please keep all hardware out of reach of small children

STEP 5

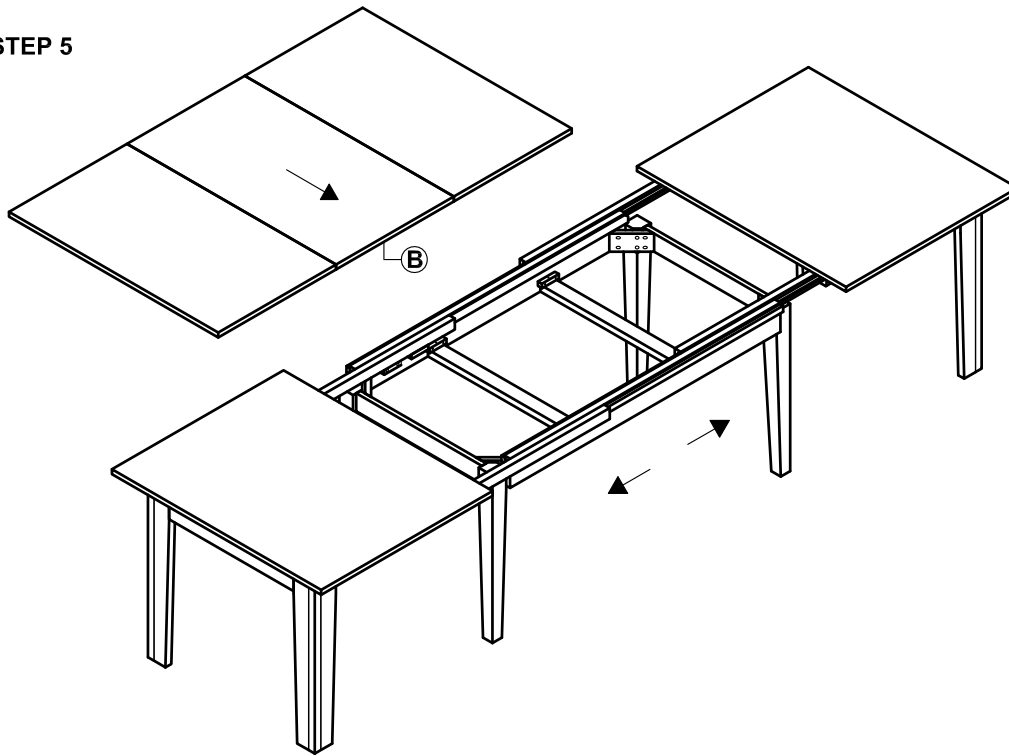

STEP 6

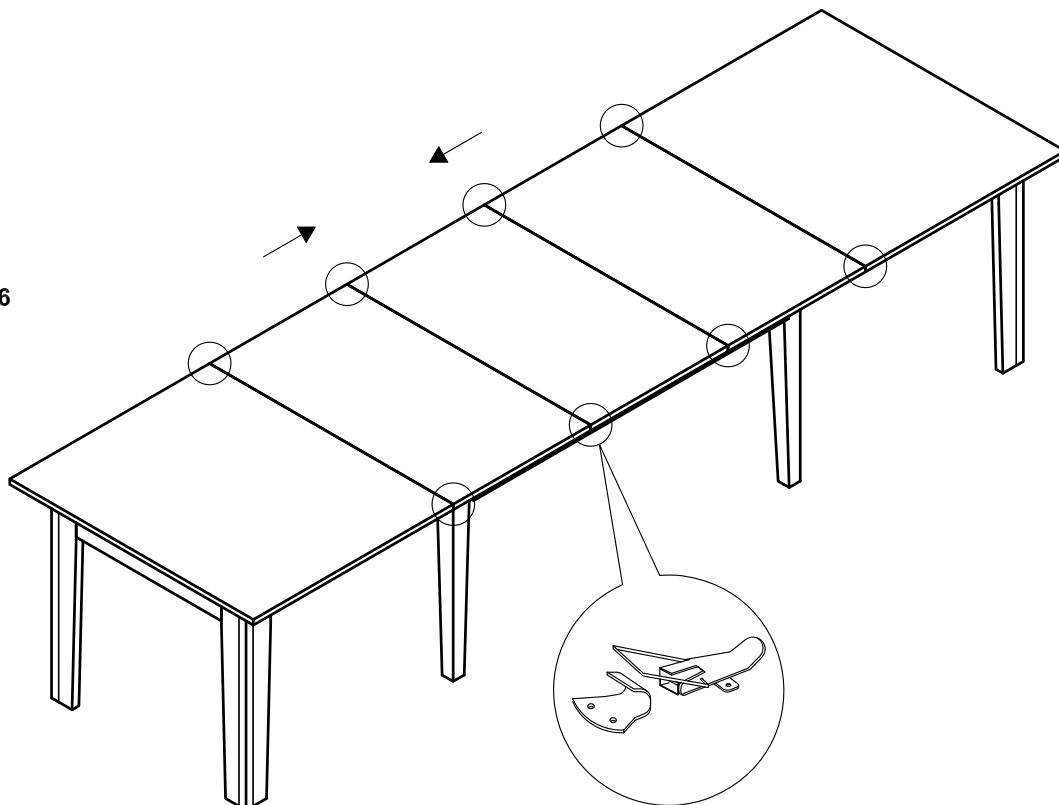

MADE IN VIETNAM

ASSEMBLY INSTRUCTIONS

ITEM NO : KA- TA- 38130- RAI- TOP







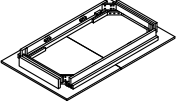
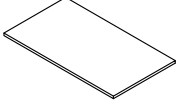
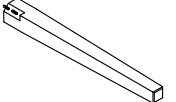
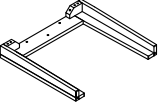
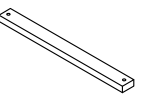

KA- TA- 38130- RAI- BSE

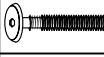
Thank you for purchasing this quality product. Be sure to check all packing material carefully for small parts that may have come loose inside the carton during shipment. Please keep all hardware out of reach of small children

PARTS LIST :

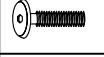
NO.	DESCRIPTION	SKETCH	QTY
A	Table Top		1 pc
B	Table Leaf		3 pcs
C	Table Leg (inside)		4 pcs
D	Table Leg (outside)		2 pcs
E	Bottom Rail		2 pcs

HARDWARE LIST :

NO.	DESCRIPTION	SIZE	SKETCH	QTY
F	Bolt	$\phi 5/16$ "x 57mm		4 pcs
G	Flat Washer	$\phi 5/16$ "x $\phi 19$ mm		22 pcs
H	Spring Washer	$\phi 5/16$ "x $\phi 12$ mm		22 pcs
I	Allen Wrench	58x 23x 4mm		1 pc
J	Bolt	$\phi 5/16$ "x 38mm		6 pcs
K	Hex Nut	$\phi 5/16$ "x 12mm		8 pcs
L	Bolt	$\phi 1/4$ "x 45mm		4 pcs
M	Wrench	12x 75mm		1 pc

STEP 1

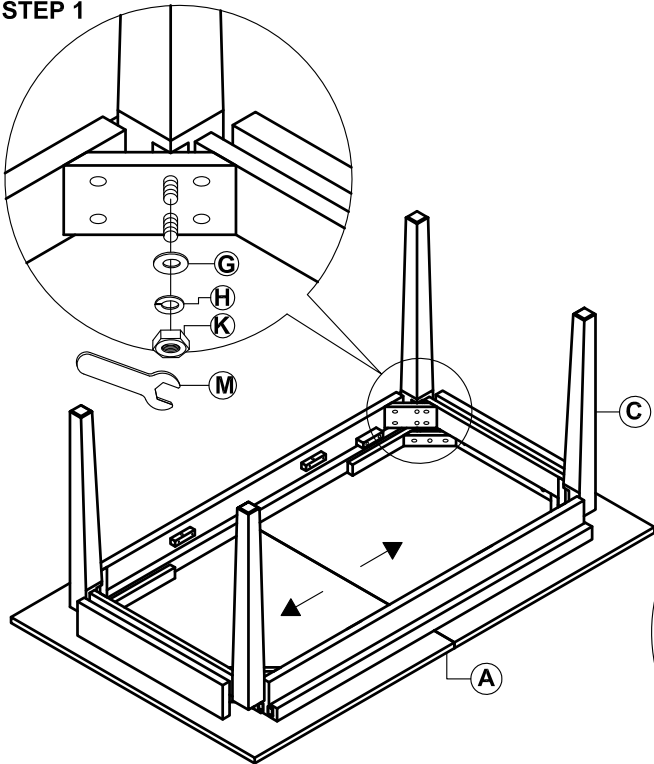

STEP 2

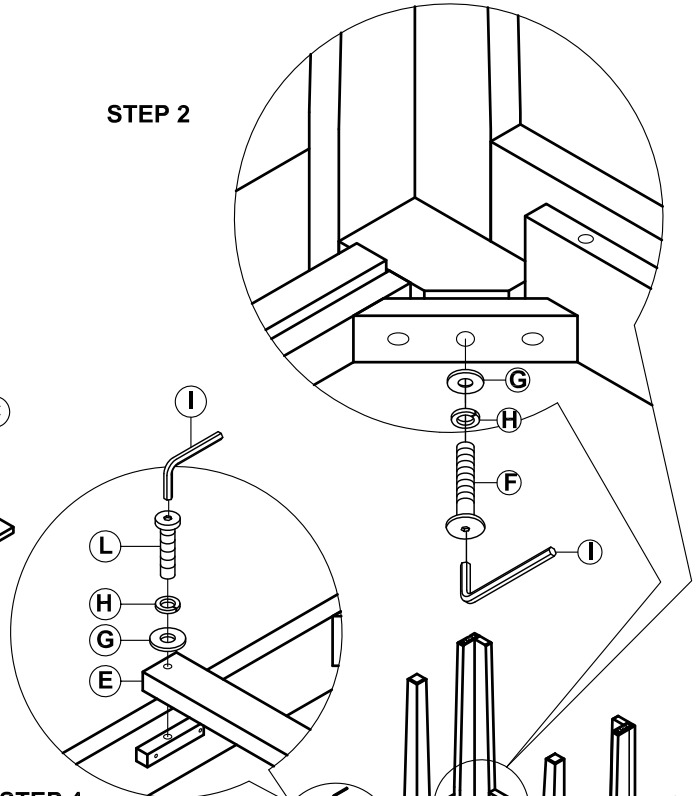

STEP 3

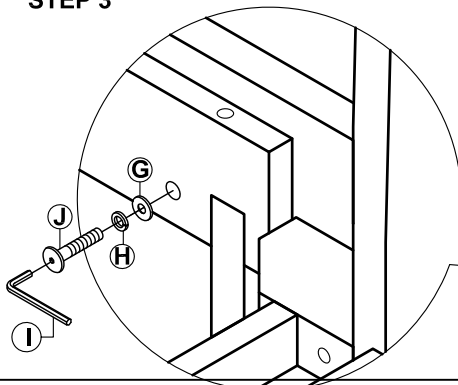

STEP 4

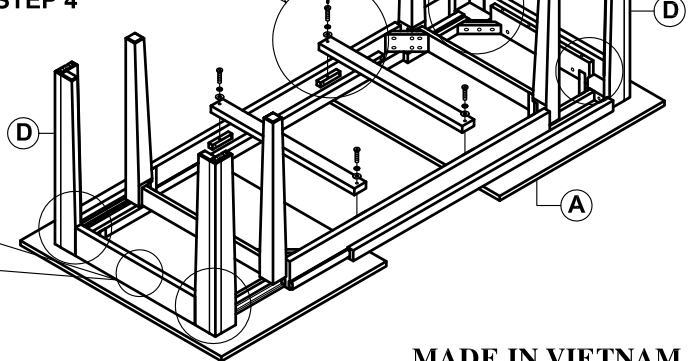

MADE IN VIETNAM