

ASSEMBLY INSTRUCTIONS

ITEM NO : KA-CA-CI5836-RAI-C

Thank you for purchasing this quality product. Be sure to check all packing material carefully for small parts that may have come loose inside the carton during shipment. Please keep all hardware out of reach of small children

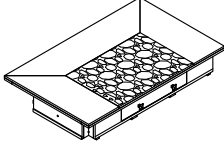
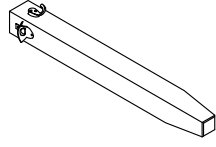
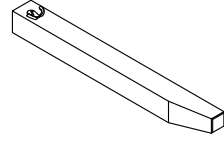
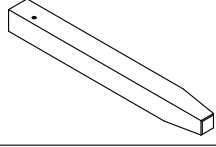
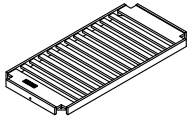

PARTS LIST :

NO.	DESCRIPTION	SKETCH	QTY
A	Culinary Island		1 pc
B	Leg		1 pc
C	Leg		1 pc
D	Leg Left & Right		2 pcs
E	Bottom Shelf		1 pc

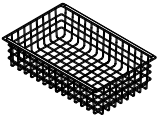
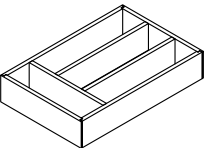
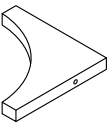
PARTS LIST :

NO.	DESCRIPTION	SKETCH	QTY
F	Wire Basket		3 pcs
G	Hardware in Drawer		1 pc
H	Piece Wood		2 pcs

HARDWARE LIST :

NO.	DESCRIPTION	SIZE	SKETCH	QTY
I	Long Bolt	φ1/4"x 55mm		16 pcs
J	Flat Washer	φ5/16"x φ19mm		4 pcs
K	Small Wassher	Ø1/4" x 12 mm		12 pcs
L	Spring Washer	φ5/16"x φ12mm		16 pcs
M	Allen Key			1 pcs

STEP 1

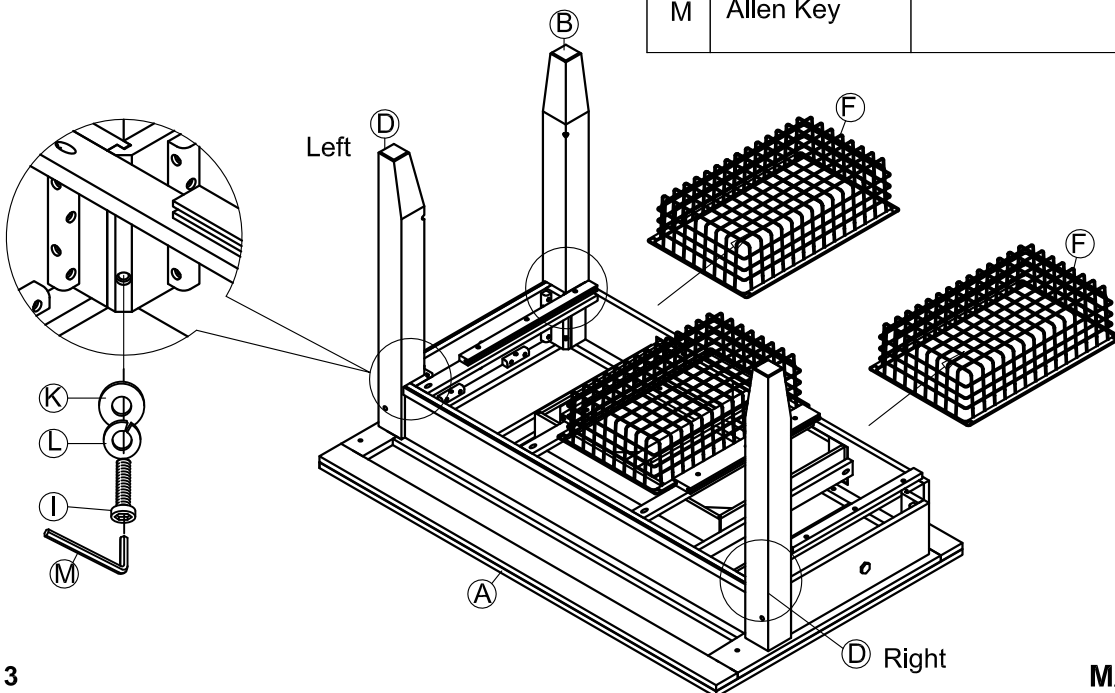

ASSEMBLY INSTRUCTIONS

ITEM NO : KA-CA-CI5836-RAI-C

STEP 2

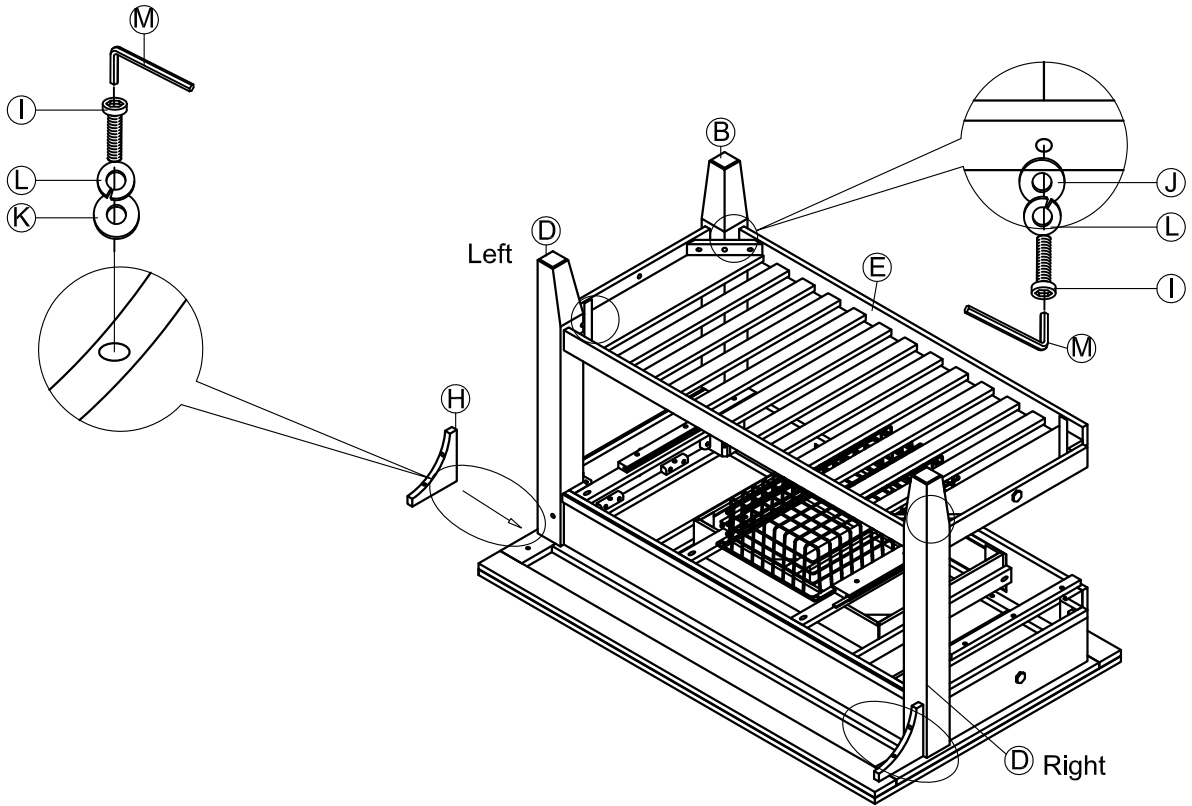

STEP 3

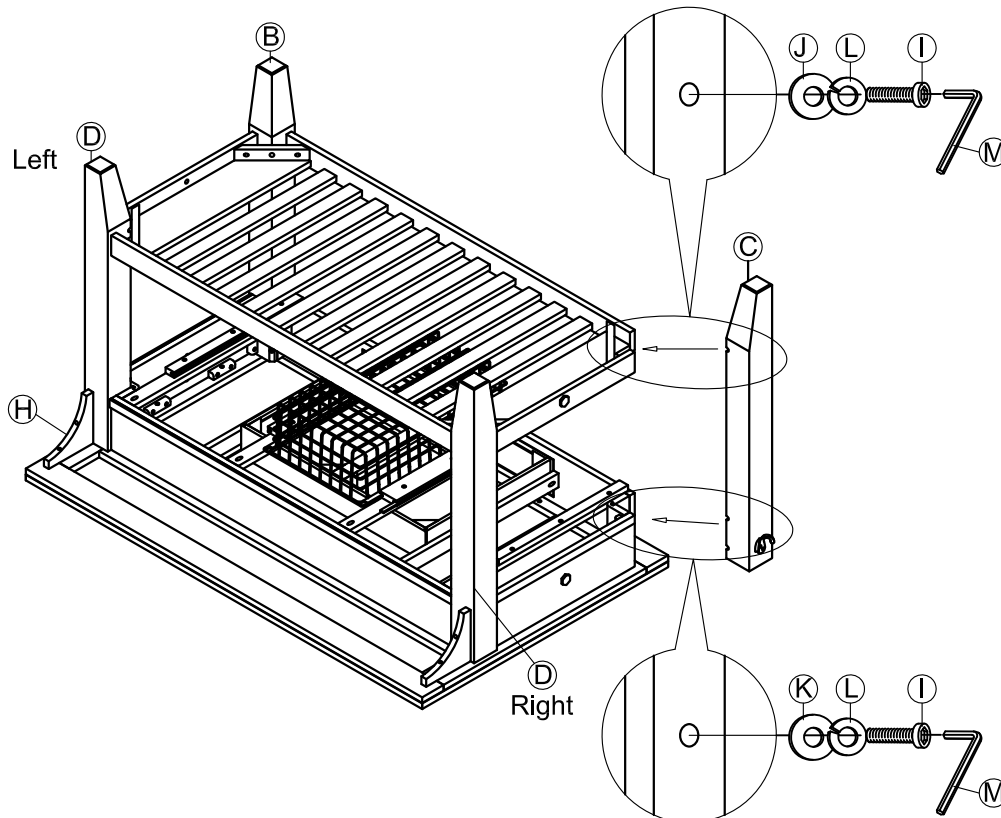

ASSEMBLY INSTRUCTIONS

ITEM NO : KA-CA-CI5836-RAI-C

STEP 4

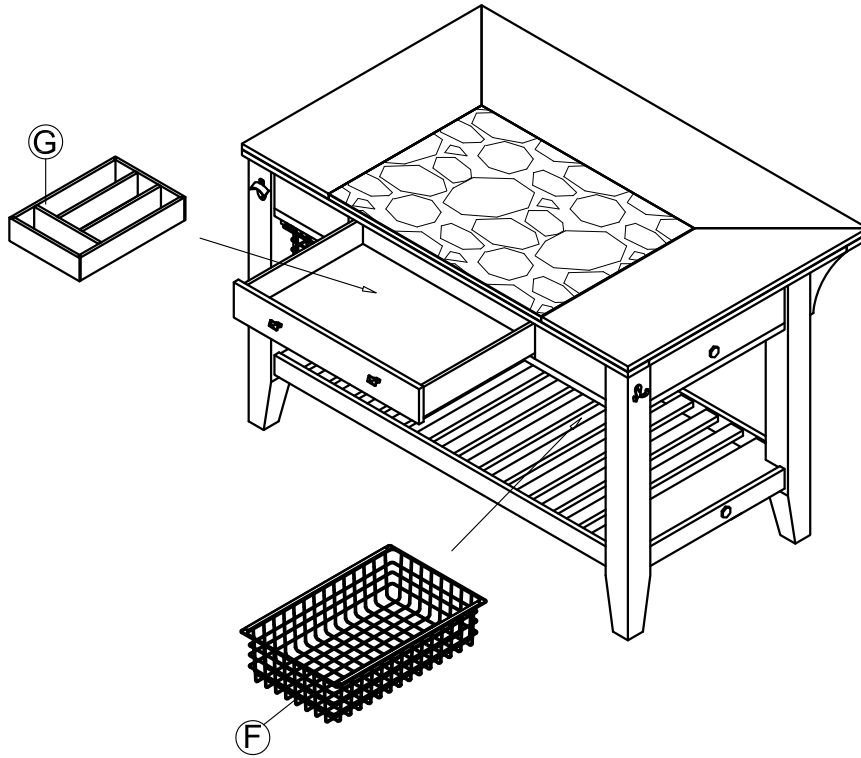

STEP 5

