

ASSEMBLY INSTRUCTION

Item No : GW-CH-689-RBC-RTA

GW-CH-689-RWC-RTA

Description : LADDER BACK CHAIR



IMPORTANT NOTE :

- Place all wooden parts on a clean and smooth surface such as a rug or carpet to avoid the parts from being scratched.
- Check to be sure that you have all parts and hardware.
- Remove all wrapping materials, including staples & packing straps before you start to assemble.
- Do not tighten all screws / bolts until all completely assembled.
- Keep all hardware parts out of reach of children.

EACH CHAIR

COMPONENT LIST

NO	DESCRIPTION	QTY
1	BACK REST	1 PC
2	BOX FRAME WITH SEAT	1 PC
3	FRONT LEG (L&R)	2 PCS

HARDWARE LIST

NO	DESCRIPTION	QTY
A	JCBC SCREW M6 x 80mm	4 PCS
B	JCBC SCREW M6 x 40mm	2 PCS
C	HEXAGON NUT 5/16"	4 PCS
D	SPRING WASHER 5/16"	10 PCS
E	FLAT WASHER 5/16"x 22mm	10 PCS
F	ALLEN KEY M4	1 PC
G	WRENCH 12.8	1 PC

NOTE : YOU WILL ALSO NEED A PHILIP SCREW DRIVER (NOT PROVIDED)

Step 1 :

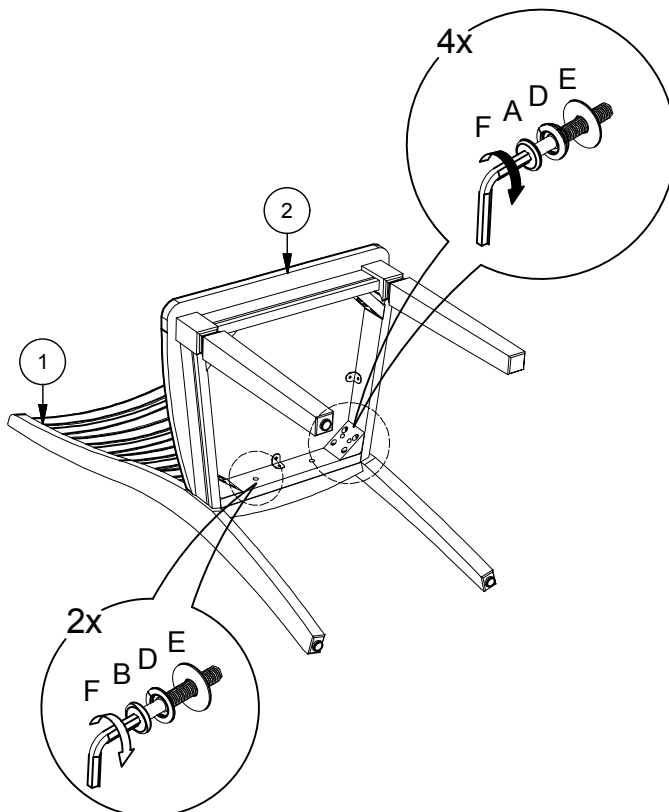

Step 2 :

