

# ASSEMBLY INSTRUCTIONS

ITEM NO : DT-TA-2426-CCR-C



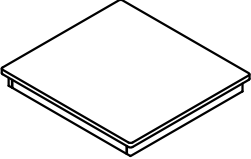
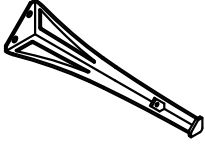
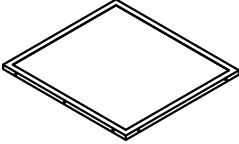

END TABLE

Thank you for purchasing this quality product. Be sure to check all packing material carefully for small parts that may have come loose inside the carton during shipment. Please keep all hardware out of reach of small children

PARTS LIST :

NO.	DESCRIPTION	SKETCH	QTY
A	Table Top		1 pc
B	Table Leg		4pcs
C	Bottom Shelf		1 pc

HARDWARE LIST :

NO.	DESCRIPTION	SIZE	SKETCH	QTY
D	Long Bolt	Ø5/16"x 32mm		8pcs
E	Spring Washer	Ø5/16"x12mm		12pcs
F	Flat Washer	Ø5/16"x19mm		12pcs
G	Allen Wrench	58x 23x 4mm		1 pc
H	Short Bolt	Ø1/4"x 19mm		4pcs

STEP 1

DO NOT TIGHTEN BOLTS UNTIL TABLE IS COMPLETELY ASSEMBLED.

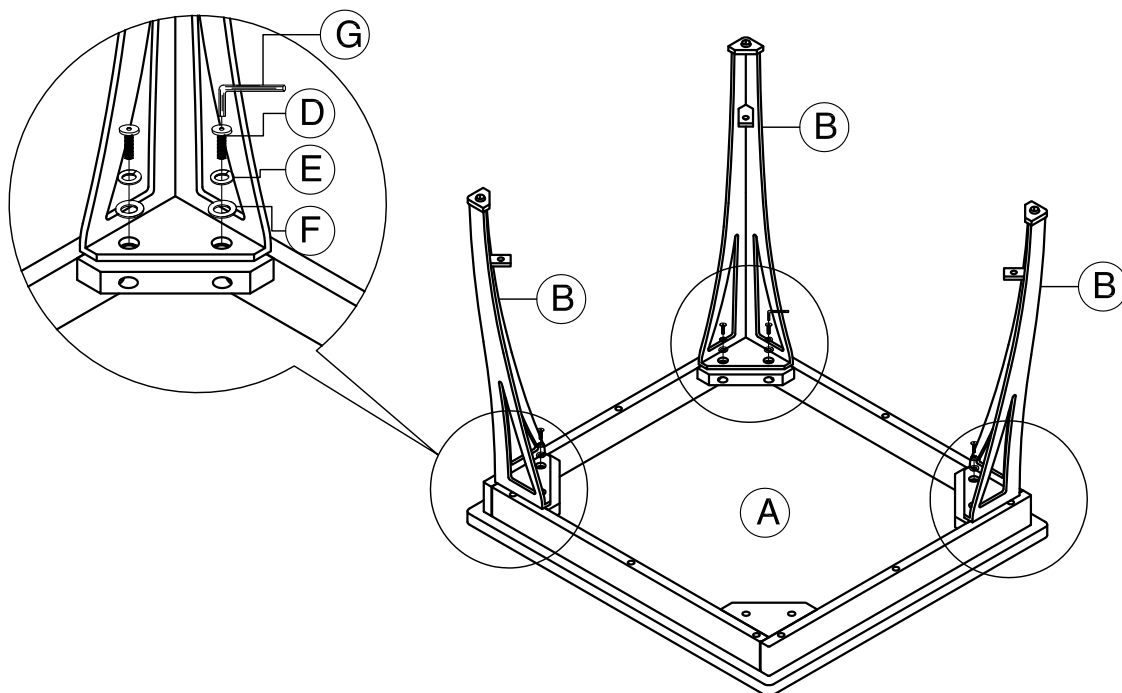

MADE IN VIETNAM

# ASSEMBLY INSTRUCTIONS

ITEM NO : DT-TA-2426-CCR-C

END TABLE

## STEP 2

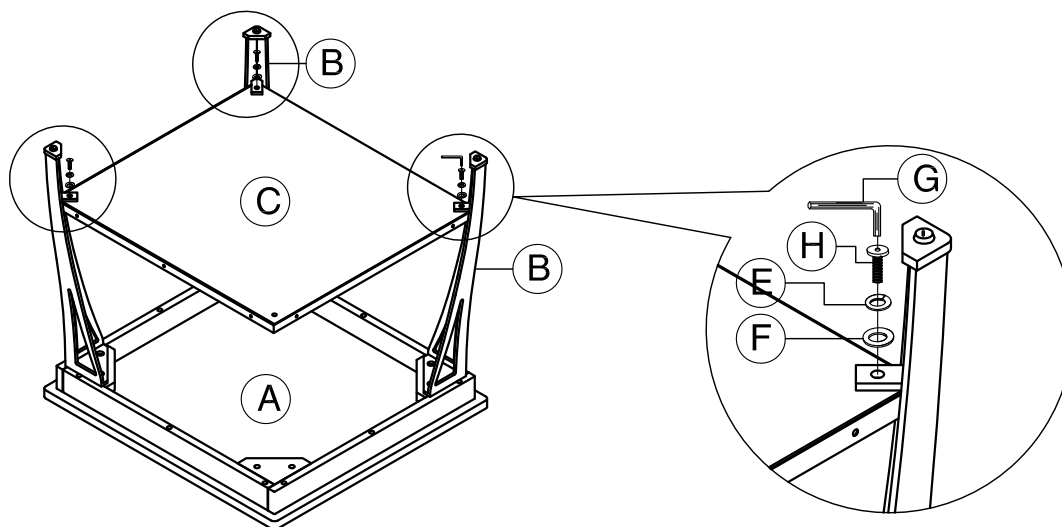

## STEP 3

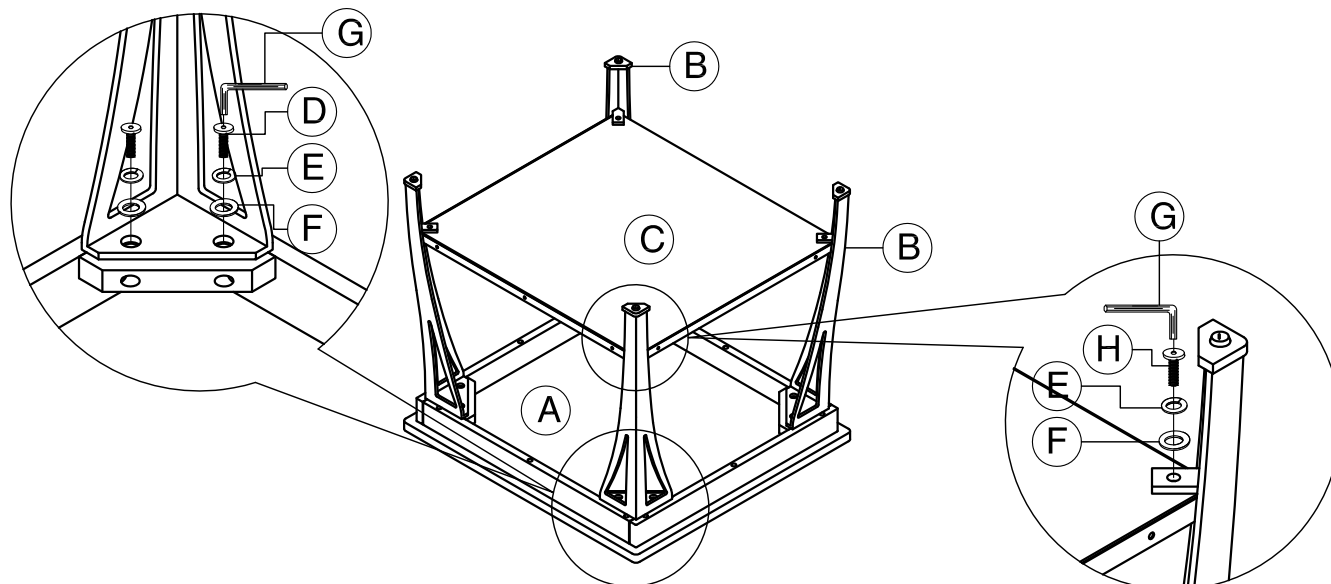

## STEP 4

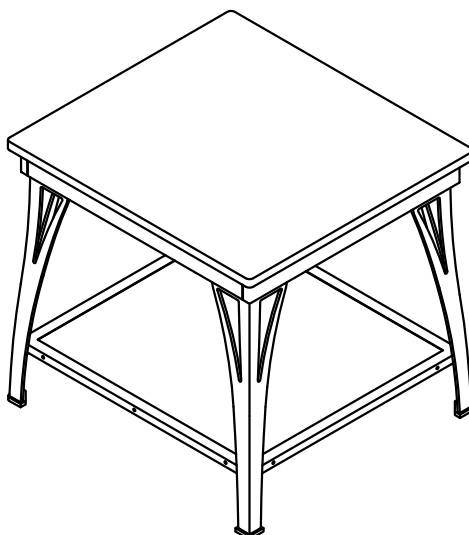

PLEASE TIGHTEN ALL BOLTS FIRMLY AND MAKE SURE THE TABLE DOES NOT WOBBLE

MADE IN VIETNAM