

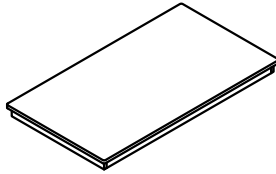

ASSEMBLY INSTRUCTIONS



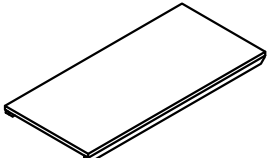
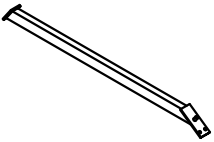

ITEM NO : DT-TA-5028-CCR-TOP / DT-TA-5028-CCR-BSE
COFFEE TABLE TOP / COFFEE TABLE BASE

Thank you for purchasing this quality product. Be sure to check all packing material carefully for small parts that may have come loose inside the carton during shipment. Please keep all hardware out of reach of small children

PARTS LIST :

NO.	DESCRIPTION	SKETCH	QTY
A	Table Top		1 pc
B	Table Leg		2pcs
C	Bottom Shelf		1 pc
D	Bottom Rail		2 pcs

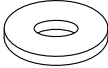
HARDWARE LIST :

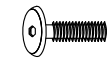
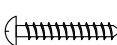
NO.	DESCRIPTION	SIZE	SKETCH	QTY
E	Long Bolt	Ø1/4"x 25mm		8pcs
F	Spring Washer	Ø5/16"x12mm		14pcs
G	Flat Washer	Ø5/16"x19mm		14pcs
H	Allen Wrench	58x 23x 4mm		1 pc
I	Short Bolt	Ø1/4"x 19mm		6pcs
J	Screw	Ø8x Ø4x 16mm		4pcs

STEP 1

DO NOT TIGHTEN BOLTS UNTIL TABLE IS COMPLETELY ASSEMBLED.

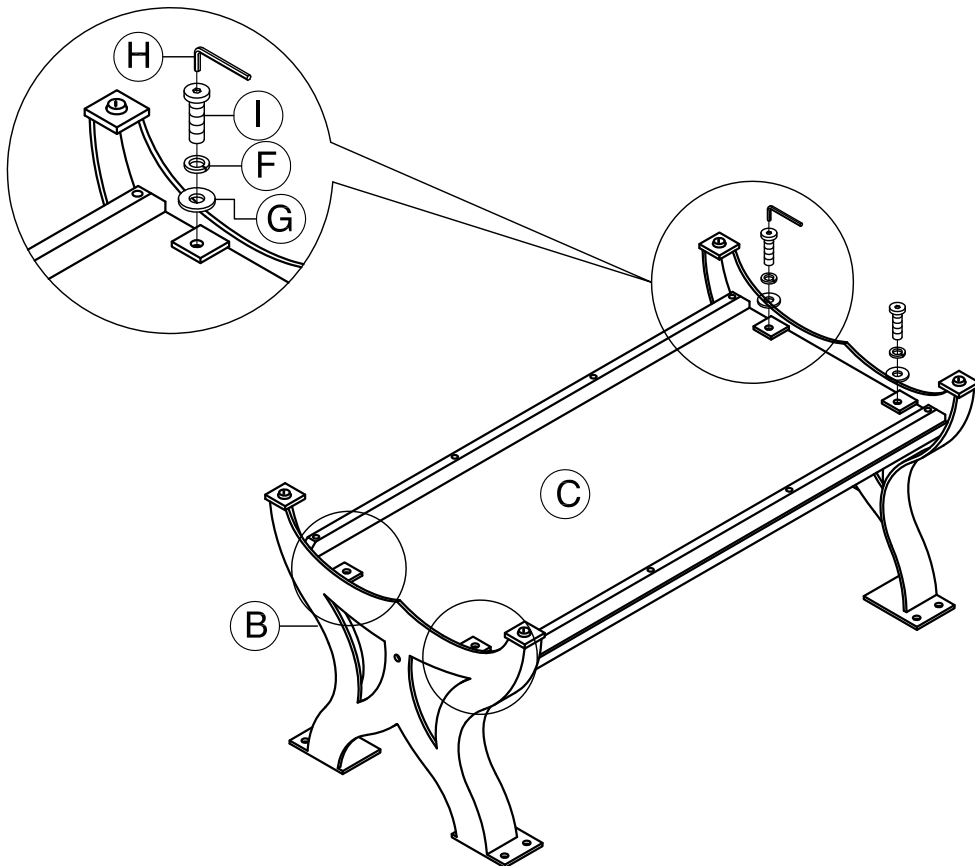

MADE IN VIETNAM

ASSEMBLY INSTRUCTIONS

ITEM NO : DT-TA-5028-CCR-TOP / DT-TA-5028-CCR-BSE
COFFEE TABLE TOP / COFFEE TABLE BASE

STEP 2

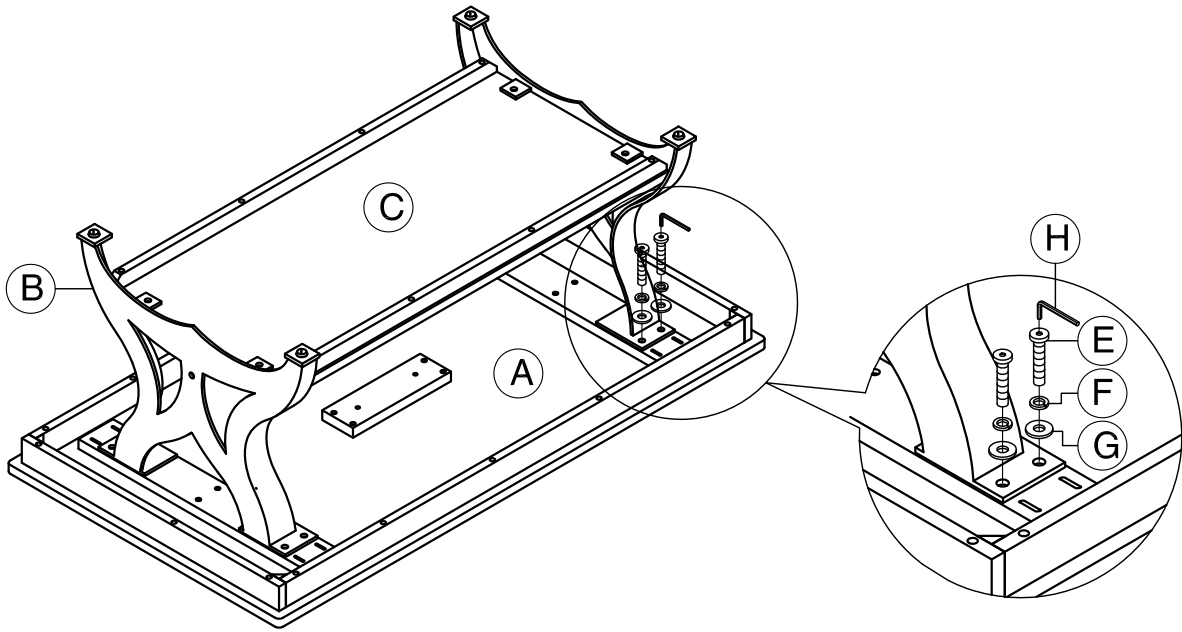

STEP 3

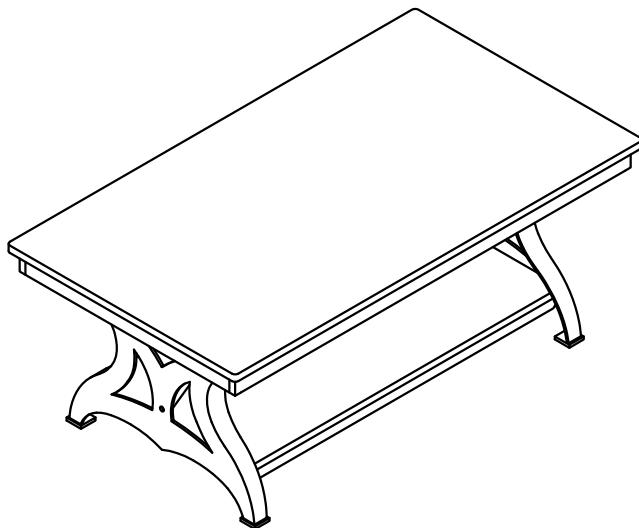
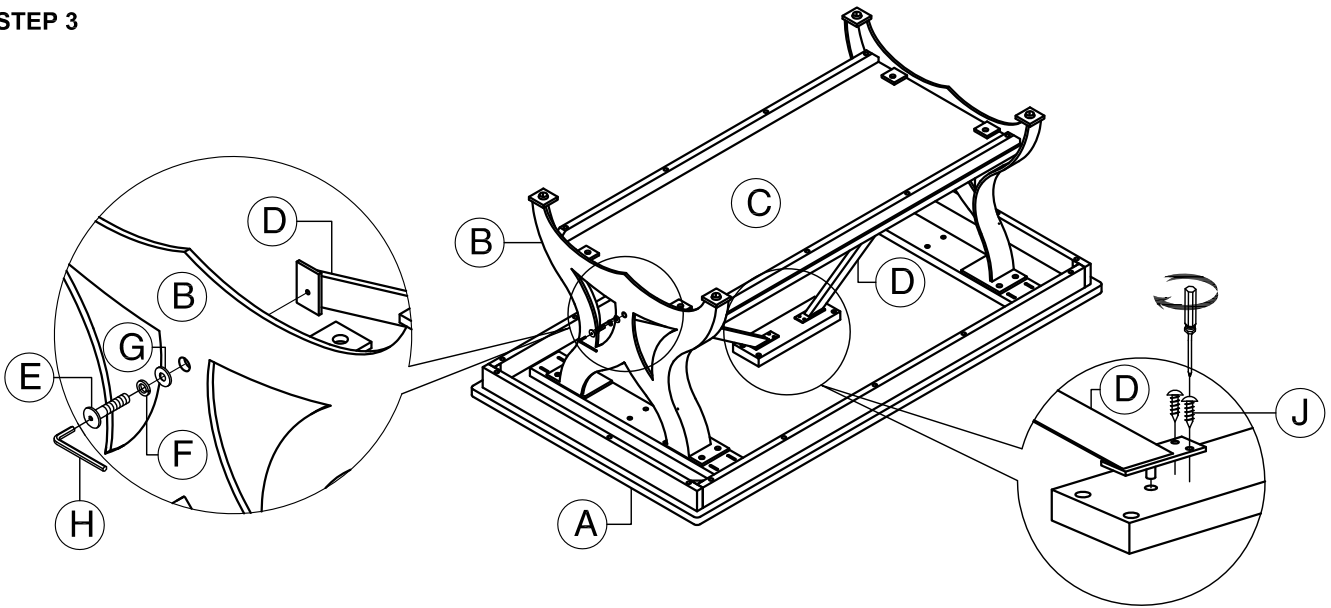

PLEASE TIGHTEN ALL BOLTS FIRMLY AND MAKE SURE THE TABLE DOES NOT WOBBLE

MADE IN VIETNAM