

Assembly Instructions

Thank you for purchasing this quality product. Carefully check all packing material for small parts which may have come loose inside the carton during shipment. Keep all hardware out of the reach of children. Study all of the instructions and drawings carefully before assembly. Check that all of the connections are tight and the product does not wobble before using.

Model: CO-TA-I4078B-BRU-TOP 40 x 60-78 Gathering Top

Model: CO-TA-I4078B-BRU-BSE 40 x 60-78 Gathering

Step 1. Turn the pedestal upside down. Do not remove the plastic bolt protectors for this step. Connect the bridge between two pedestals by using two Nuts, two Flat Washers and two Lock Washers provided. Tighten all nuts firmly with the wrench provided. (Figure 1)

Step 2. Remove the plastic bolt protectors from the hanger bolts on the legs. Attach each leg to the pedestal using eight Nuts, eight Flat Washers and eight Lock Washers and tighten firmly with the wrench provided. (Figure 1)





Step 3. Turn the assembled pedestal base right side up and place it in your desired location. Adjust the leg levelers at the bottom of each leg so that the pedestal remains solid without rocking. Remove the plastic bolt protectors before doing the next step.(Figure 3)

Please remove 2pcs metal brackets secured the slides to the top bottom before the next step. (Figure 2)

Step 4. Place the open table top over the pedestal and align the holes in the table mounting boards with the bolts on the pedestal. Set the table down on the top of the pedestal. (Figure 3)

Step 5. Attach the pedestal to the mounting board as shown using six Nuts, six Flat Washers and six Lock Washers. Tighten all nuts firmly with the wrench provided. (Figure 3)

*Check that all legs are tight and the table does not wobble before using.

HARDWARE CHECK LIST	
Quantity	PART NAME
18	Nut 
18	Flat Washer 
18	Lock Washer 
1	Wrench 

PARTS CHECK LIST	
Quantity	PART NAME
1	Top
2	Pedestal
1	Bridge
4	Leg

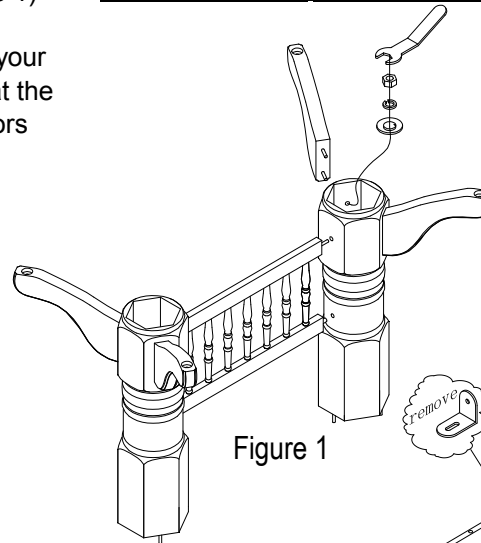

Figure 1

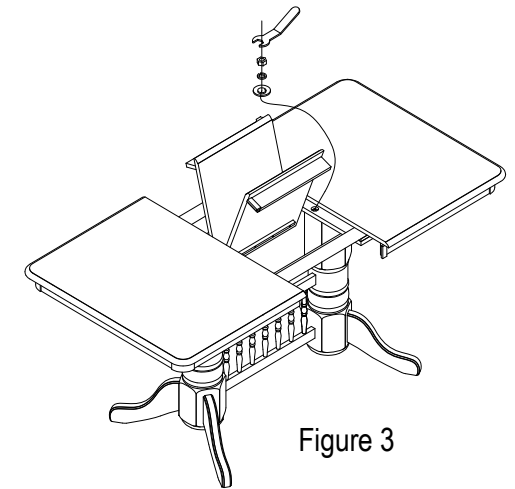

Figure 3

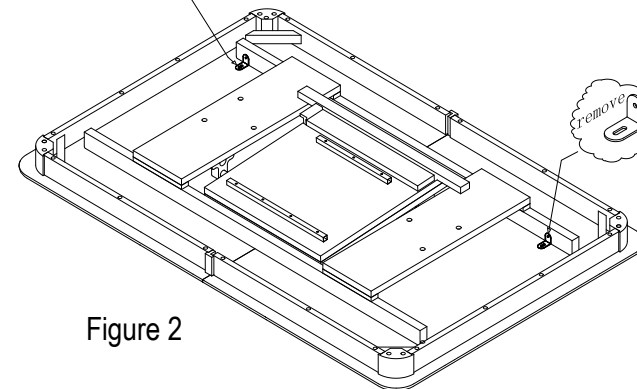

Figure 2