

ASSEMBLY INSTRUCTION

For Model :

AR - CH - 185B - BLJ - RTA

AR - CH - 185B - JAV -RTA

AR - CH - 185B - WHJ - RTA

Description : Lattice Back Bench

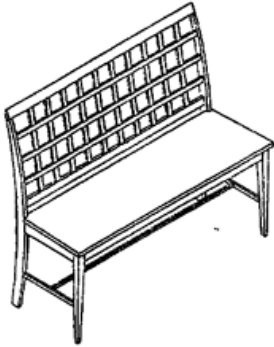

IMPORTANT NOTE:

- Place all wooden parts on a clean and smooth surface such as a rug or carpet to avoid the parts from being scratched.
- Check to be sure that you have all parts and hardware.
- Remove all wrapping materials, including staples & packing straps before you start to assemble.
- Do not tighten all screws / bolts until all completely assembled.
- Keep all hardware parts out of reach of children.

Each Bench

PARTS LIST

NO	DESCRIPTION	QTY
1	BACK REST	1 PC
2	BOX FRAME	1 PC
3	FRONT LEG (Left & Right)	2 PCS
4	SIDE STRETCHER (Left & Right)	2 PCS
5	CENTER STRETCHER	1 PC
6	WOODEN SEAT	1 PC

HARDWARE LIST

NO	DESCRIPTION	QTY
A	JCBC SCREW M6 x 80mm	4 PCS
B	JCBC SCREW M6 x 60mm	4 PCS
C	JCBC SCREW M6 x 40mm	5 PCS
D	SPRING WASHER Ø8 x 15mm	13 PCS
E	FLAT WASHER Ø8 x 22mm	13 PCS
F	ALLEN KEY M4	1 PC
G	CSK SCREW M4 x 20mm	2 PCS
H	CSK SCREW M4 x 32mm	11 PCS

Step : 1

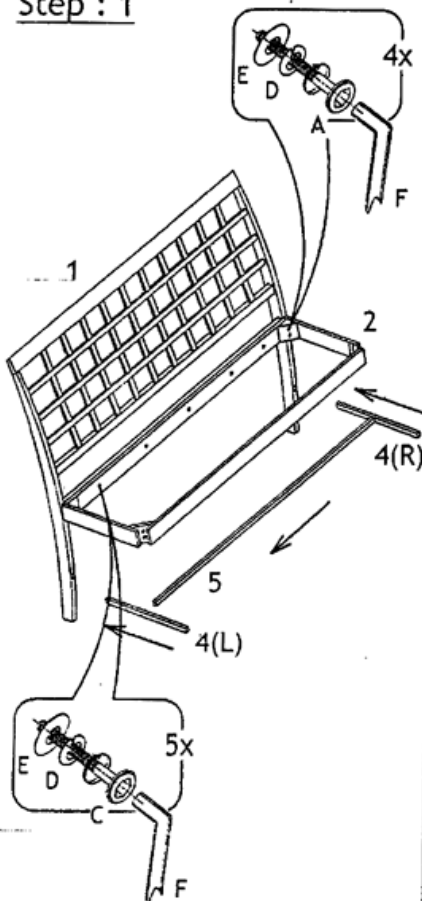

Step : 2

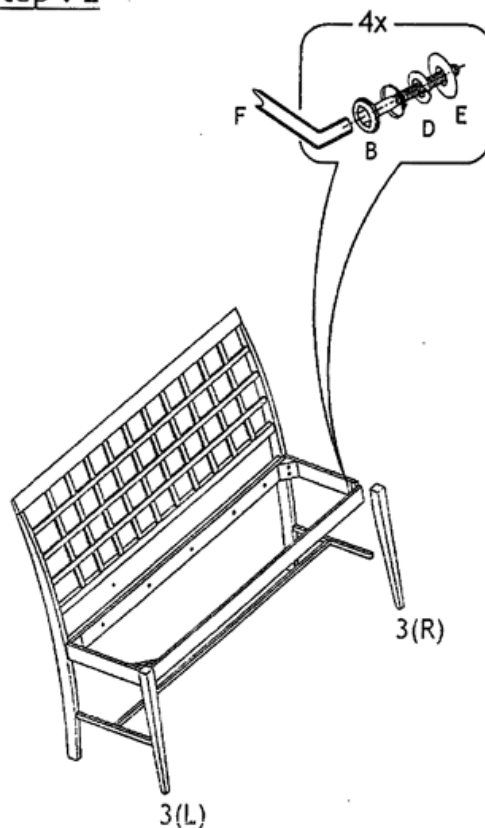

Step : 3

